

752™ High-Torque DC drilling motor

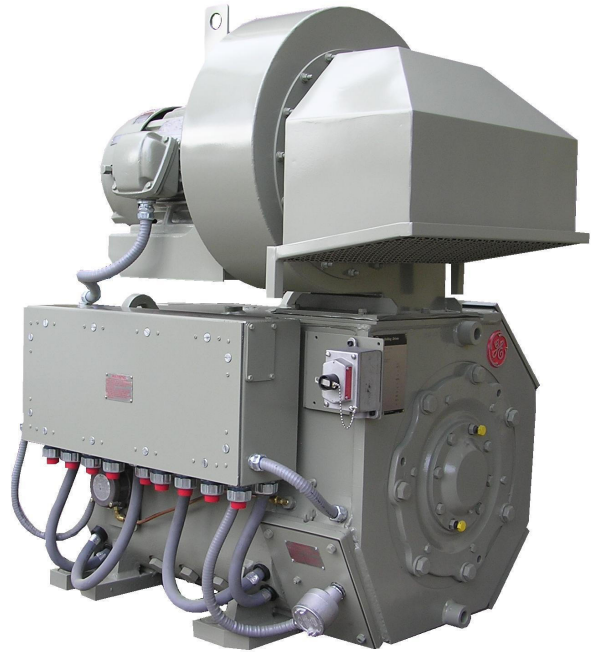

Performance ratings

The 752 High-Torque DC drilling motor with 2800 SCFM airflow and temperature rise of 155°C at 40°C ambient.

	Continuous Max. Hp	Drawworks Duty Cycle
Shunt Wound		
Volts (dc)	750	750
Arm amps	1185	1435
Field amps	60	60
RPM	1040	1065
Torque (lb ft)	5705	6745
Hp	1130	1365
Series Wound		
Volts (dc)	750	750
Arm amps	1150	1400
RPM	965	920
Torque (lb ft)	5900	7530
Hp	1085	1320

To find out more fax inquiries to 832-295-7600
or visit us online at www.getransportation.com

Standard features

- Class H insulation
- Single shaft extension with hub
- Pressurized connection box with double bolt-on cable connections and terminations for motor auxiliaries
- Space heater.
- Auxiliary lockout switch
- Pressure sensor.
- Blower assembly with 10 Hp motor

Marine models also include:

- Two 100 Ohm platinum RTDs
- ABS certified shaft.
- Armored cable.

Optional features:

- Plug-in connectors
- Encoder
- ABS certification
- Closed loop cooling
- 15 Hp blower assembly
- SS connection box
- Spark arrester
- Noise attenuation
- Intake air filter



GE Transportation

GE752 shunt wound drilling motor
60 amp field at 2800 scfm ventilation

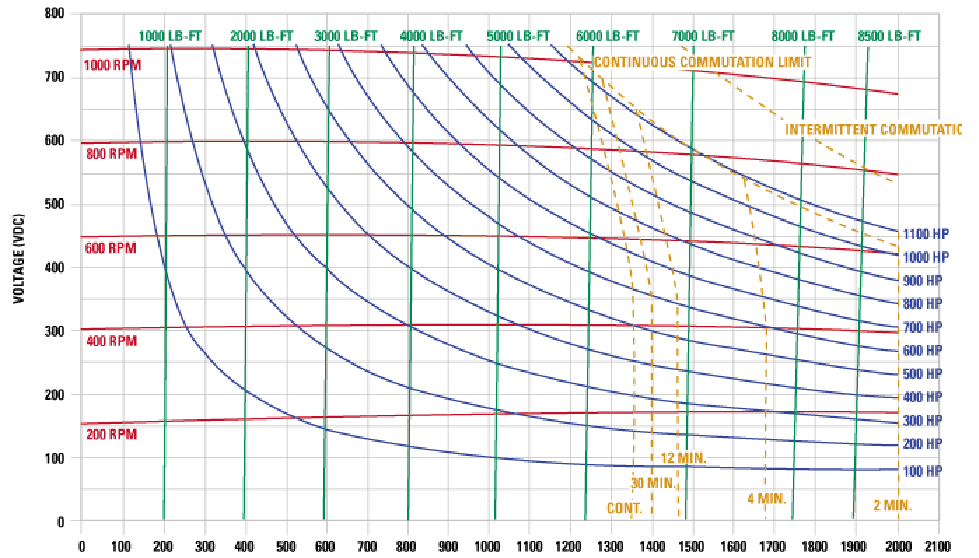

GE752 series wound drilling motor
at 2800 scfm ventilation

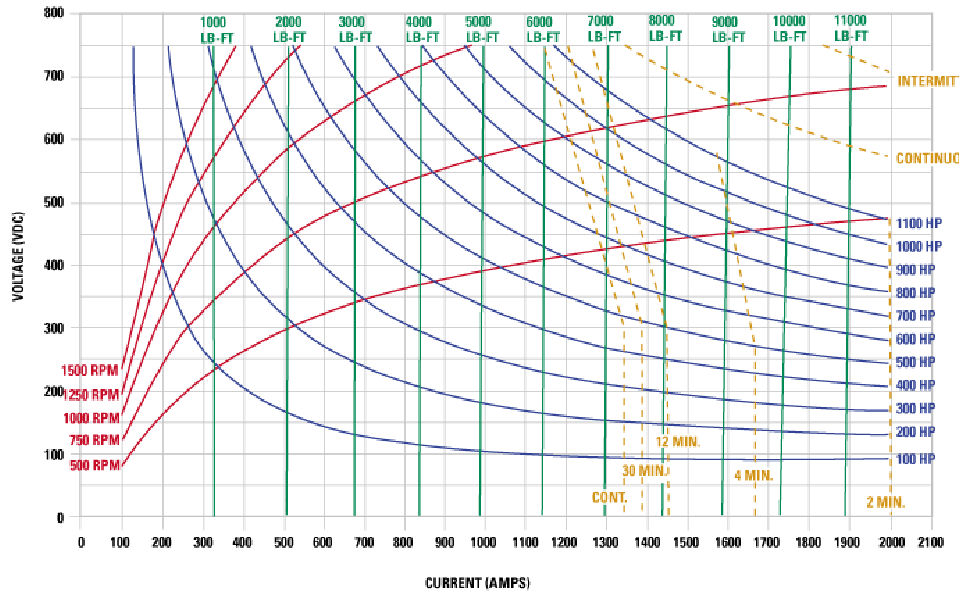

Approximate Weight: 7200 lbs.

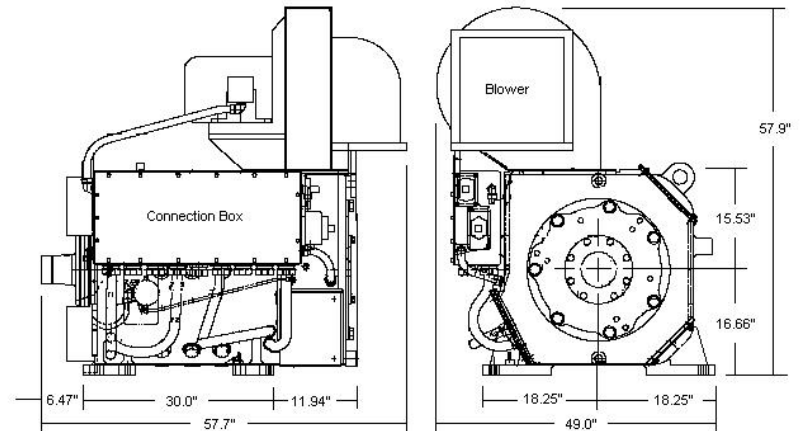

Dimensions are approximate. Not for construction.



imagination at work